

PRODUCT SPECIFICATION SHEET

Product	UN Mark
<b>VEV1600 16ltr Rectangular Bucket</b>	N/A

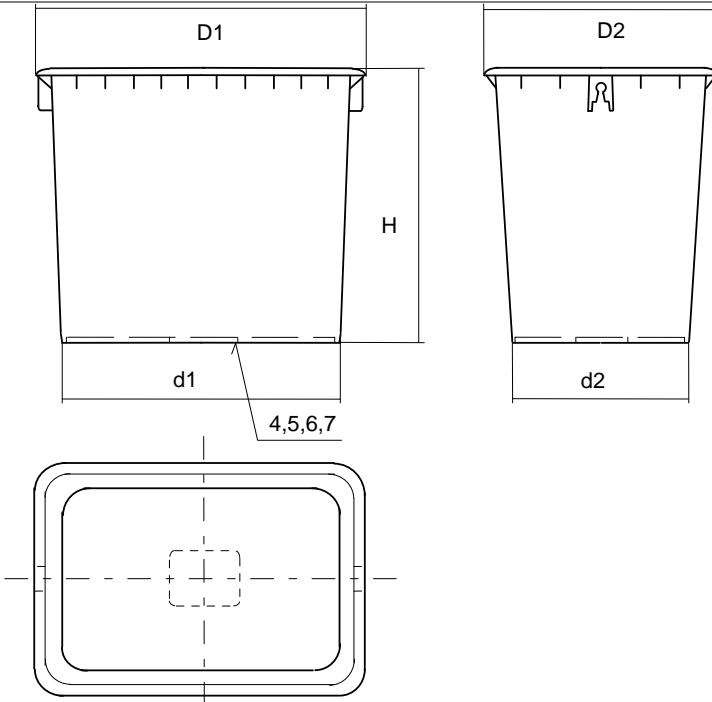

Bucket	
Material	High Density Polyethylene
Fabrication	Injection moulded
Handle	Metal
Nominal Capacity	16ltr
Brimful Capacity	18.6ltr
Nominal Weight	620g +/-20
Pallet Quantity	250
Pallet Size	1200x800x1600mm
Weight per Pallet	205kg
Stock Colours	Non stock item 2-3 week lead-time

Dimensions	mm	Lid - DEV16	
Height	283 +/-1%	Material	Low Density Polyethylene
Top 'D1'	352 +/-1%	Fabrication	Injection moulded
Top 'D2'	248 +/-1%	Height	14mm +/-1%
Base 'd1'	297 +/-1%	Dimensions	365mm x 252mm +/-1%
Base 'd2'	187 +/-1%	Nominal Weight	210g +/-5
		Pack Size	50 per bag
		Stock Colours	Non stock item 2-3 week lead-time

Additional Information
4 pallet minimum order for coloured buckets Printing available please contact us for a quotation

PPREF	Issue	Date of Issue	Approved By
AT	A	08/05/07	Roy Miller

**UNCONTROLLED COPY**