

PRODUCT SPECIFICATION SHEET

Product	UN Mark	
SC1330 30ltr UN Bucket	1H2/Y32/S/**/I IPZS	
	SC1330A	

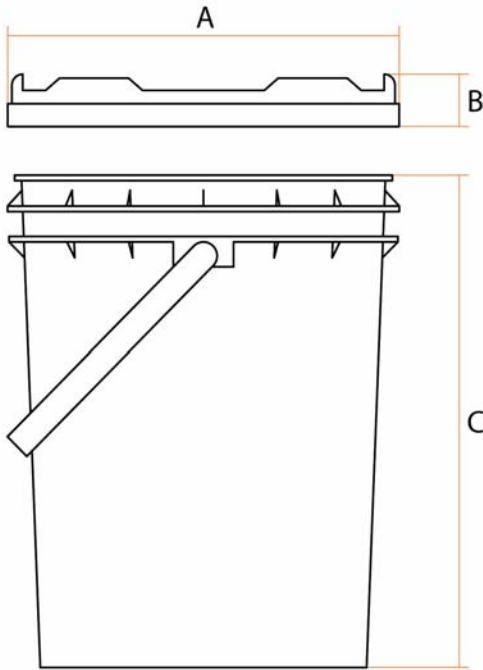

Bucket	
Material	High Density Polyethylene
Fabrication	Injection moulded
Handle	Black Plastic
Nominal Capacity	30ltr
Brimful Capacity	32ltr +/-0.80
Nominal Weight	1095g +/-5%
Pallet Quantity	180
Pallet Size	1000x1200mmx2200mm
Weight per Pallet	
Stock Colours	Non stock item 3 week lead-time

Dimensions	mm	Lid - CO1330	
Lid Diameter 'A'	370 +/-2.5	Material	Mixed Density Polyethylene
Lid Height 'B'	31 +/-0.5	Fabrication	Injection moulded
Bucket Height 'C'	290 +/-1.8	Height	31mm +/-0.5
Bucket Top Diameter	367 +/-2.5	External Dia	370 +/-2.5
Bucket Base Diameter	318 +/-2.5	Nominal Weight	330g +/-5%
		Pack size	packed on top of buckets
		Stock Colours	Non stock item 3 week lead-time

Additional Information

PPREF	Issue	Date of Issue	Approved By
IT	A	08/05/07	Roy Miller

**UNCONTROLLED COPY**