

PRODUCT SPECIFICATION SHEET

Product	UN Mark	
SC1325 23.5ltr UN Bucket	1H2/Y27/S/**/I IPZS	
	SC1325	

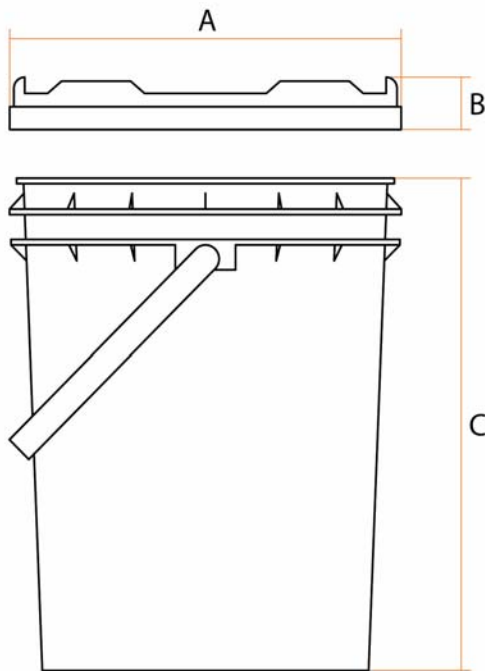

Bucket	
Material	High Density Polyethylene
Fabrication	Injection moulded
Handle	Black Plastic
Nominal Capacity	23.5ltr
Brimful Capacity	25.4ltr +/-0.61
Nominal Weight	847g +/-5%
Pallet Quantity	240
Pallet Size	1000x1200mmx2000mm
Weight per Pallet	
Stock Colours	Non stock item 3 week lead-time

Dimensions	mm	Lid - CO1325	
Lid Diameter 'A'	338.5 +/-2.5	Material	Mixed Density Polyethylene
Lid Height 'B'	29 +/-0.4	Fabrication	Injection moulded
Bucket Height 'C'	345 +/-2.5	Height	29mm +/-0.4
Bucket Top Diameter	334.5 +/-2.5	External Dia	338.5 +/-2.5
Bucket Base Diameter	292.6 +/-1.8	Nominal Weight	252g +/-5%
		Pack size	packed on top of buckets
		Stock Colours	Non stock item 3 week lead-time

Additional Information

PPREF	Issue	Date of Issue	Approved By
IT	A	08/05/07	Roy Miller

UNCONTROLLED COPY