

PRODUCT SPECIFICATION SHEET

Product	UN Mark	
SC1311 10.5ltr UN Bucket	1H2/Y13/S/** I IPZS	
	SC1311A	

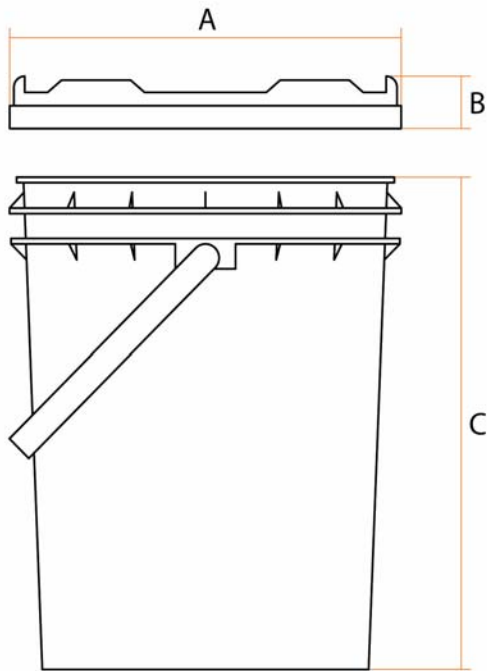

Bucket	
Material	High Density Polyethylene
Fabrication	Injection moulded
Handle	Black Plastic
Nominal Capacity	10.5ltr
Brimful Capacity	11.3ltr +/-0.51
Nominal Weight	430g +/-5%
Pallet Quantity	480
Pallet Size	1000x1200mm18200mm
Weight per Pallet	
Stock Colours	Non stock item 3 week lead-time

Dimensions	mm	Lid - CO1311	
Lid Diameter 'A'	262 +/-1.8	Material	Mixed Density Polyethylene
Lid Height 'B'	28 +/-0.4	Fabrication	Injection moulded
Bucket Height 'C'	276 +/-1.8	Height	28mm +/-0.4
Bucket Top Diameter	255 +/-1.8	External Dia	262mm +/-1.8
Bucket Base Diameter	215 +/-1.8	Nominal Weight	182g +/-5%
		Pack Size	Packed on top of buckets
		Stock Colours	Non stock item 3 week lead-time

Additional Information

PPREF	Issue	Date of Issue	Approved By
IT	A	08/05/07	Roy Miller