

PRODUCT SPECIFICATION SHEET

Product	UN Mark
SC1304 PE 4ltr UN Bucket	1H2/Y7/S/**F/BVT250508/LAR

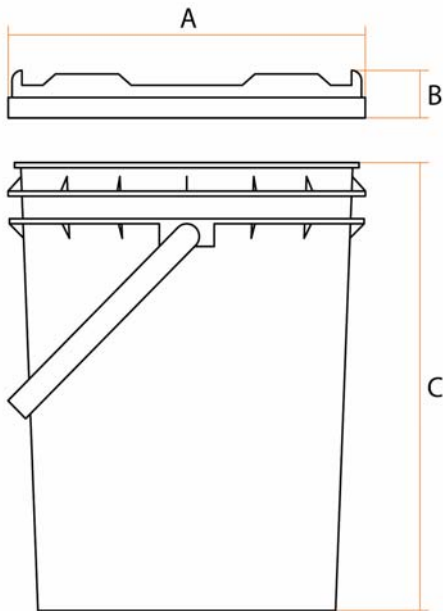

Bucket	
Material	High Density Polyethylene
Fabrication	Injection moulded
Handle	Black Plastic
Nominal Capacity	4ltr
Brimful Capacity	4.3ltr +/-0.31
Nominal Weight	207g +/-5%
Pallet Quantity	750
Pallet Size	1000x1200mmx1400mm
Weight per Pallet	
Stock Colours	Non stock item 3 week lead-time

Dimensions	mm	Lid - C01304	
Lid Diameter 'A'	192.3 +/-1.2	Material	Mixed Density Polyethylene
Lid Height 'B'	25.4 +/-0.4	Fabrication	Injection moulded
Bucket Height 'C'	195 +/-1.2	Height	25.4mm +/-0.4
Bucket Top Diameter	190 +/-1.2	External Dia	192.3mm +/-1.2
Bucket Base Diameter	158 +/-1	Nominal Weight	63g +/-5%
		Pack Size	Packed on top of buckets
		Stock Colours	Non stock item 3 week lead-time

Additional Information

PPREF	Issue	Date of Issue	Approved By
IT	A	08/05/07	Roy Miller