

PRODUCT SPECIFICATION SHEET

Product	UN Mark	
EZ1250 12.5ltr UN Round Bucket	1H2/Y12/S/Jahr/A/PA-01/ TGM-K83	

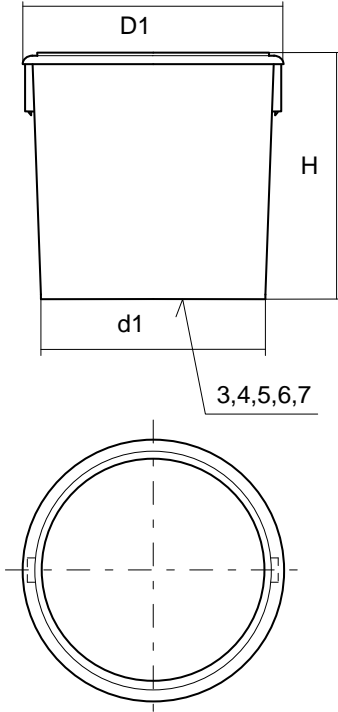

Bucket	
Material	High Density Polyethylene
Fabrication	Injection moulded
Handle	Metal
Nominal Capacity	12.5ltr
Brimful Capacity	13.6ltr
Nominal Weight	433g +/-10
Pallet Quantity	300
Pallet Size	1200x800x1800mm
Weight per Pallet	170kg
Stock Colours	Non stock item 2-3 week lead-time

Dimensions	mm	Lid - DZ1250	
Height	268 +/-1%	Material	Low Density Polyethylene
Top Diameter 'D1'	285 +/-1%	Fabrication	Injection moulded
Base Diameter 'd1'	245 +/-1%	Height	16mm +/-1%
		External Dia	290mm +/-1%
		Nominal Weight	120g +/-10
		Pack Size	50 per bag
		Stock Colours	Non stock item 2-3 week lead-time

Additional Information
4 pallet minimum order for coloured buckets Printing available please contact us for a quotation

PPREF	Issue	Date of Issue	Approved By
AT	A	08/05/07	Roy Miller

**UNCONTROLLED COPY**