

PRODUCT SPECIFICATION SHEET

Product	UN Mark	
EO550 5.5ltr UN Oval Bucket	1H2/Y6/S/..A/PA01/TGM-K81	

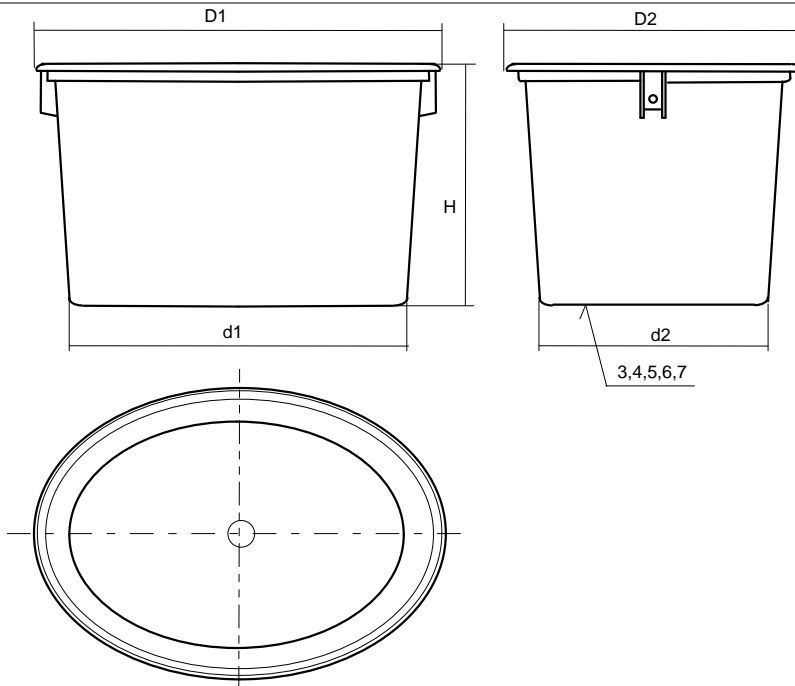

Bucket	
Material	High Density Polyethylene
Fabrication	Injection moulded
Handle	Metal
Nominal Capacity	5.5ltr
Brimful Capacity	6.6ltr
Nominal Weight	230g +/-15
Pallet Quantity	600
Pallet Size	1200x800x1650mm
Weight per Pallet	180kg
Stock Colours	Non stock item 2-3 week lead-time

Dimensions	mm	Lid - DO550	
Height	179 +/-1%	Material	Low Density Polyethylene
Top Diameter 'D1'	299 +/-1%	Fabrication	Injection moulded
Top Diameter 'D2'	219 +/-1%	Height	14mm +/-1%
Base Diameter 'd1'	251 +/-1%	External Dia's	300mm & 205mm +/-1%
Base Diameter 'd2'	173 +/-1%	Nominal Weight	94g +/-6
		Pack Size	100 per bag
		Stock Colours	Non stock item 2-3 week lead-time

Additional Information
4 pallet minimum order for coloured buckets Printing available please contact us for a quotation

PPREF	Issue	Date of Issue	Approved By
AT	A	08/05/07	Roy Miller