

PRODUCT SPECIFICATION SHEET

Product	UN Mark
EZ2000 20ltr T/E Bucket	N/A

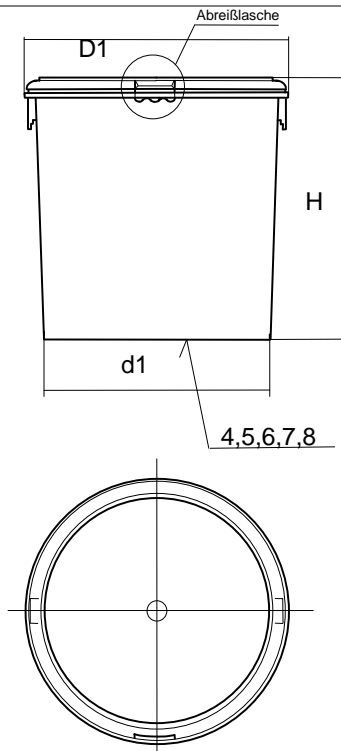

Bucket	
Material	Polypropylene Copolymer food approved
Fabrication	Injection moulded
Handle	Metal
Nominal Capacity	20ltr
Brimful Capacity	21.16ltr
Nominal Weight	570g +/-15
Pallet Quantity	192
Pallet Size	1200x800x2110mm
Weight per Pallet	150kg
Stock Colours	White

Dimensions	mm	Lid - DZ2000	
Height	303	Material	Polypropylene Copolymer food approved
Top Diameter 'D1'	335	Fabrication	Injection moulded
Base Diameter 'd1'	291	Height	16mm +/-1%
		External Dia	336 +/-1%
		Nominal Weight	158g +/-10
		Pack Size	48 per bag
		Stock Colours	White Green Red T/E and Blue NON T/E

**Additional Information**  
4 pallet minimum order for coloured buckets  
Printing available please contact us for a quotation

PPREF	Issue	Date of Issue	Approved By
AT	A	27.01.07	Roy Miller