

PRODUCT SPECIFICATION SHEET

Product	UN Mark
EZ100 1ltr T/E Bucket	N/A

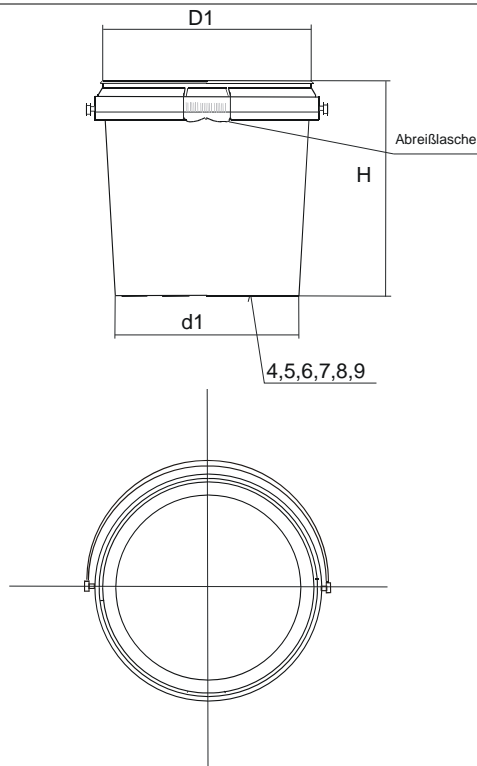

Bucket	
Material	Polypropylene Copolymer food approved
Fabrication	Injection moulded
Handle	Plastic
Nominal Capacity	1ltr
Brimful Capacity	1.3ltr
Nominal Weight	48g +/-5
Pallet Quantity	2000
Pallet Size	1200x800x1300mm
Weight per Pallet	133kg
Stock Colours	White

Dimensions	mm	Lid - DZ100	
Height	130	Material	Polypropylene Copolymer food approved
Top Diameter 'D1'	133	Fabrication	Injection moulded
Base Diameter 'd1'	105	Height	10mm +/-1%
		External Dia	128mm +/-1%
		Nominal Weight	12g +/-3
		Pack Size	400 per box
		Stock Colours	White

Additional Information
4 pallet minimum order for coloured buckets Printing available please contact us for a quotation

PPREF	Issue	Date of Issue	Approved By
AT	A	27.01.07	Roy Miller

UNCONTROLLED COPY