

PRODUCT SPECIFICATION SHEET

Product	UN Mark
EO1500 15ltr Oval T/E Bucket	N/A

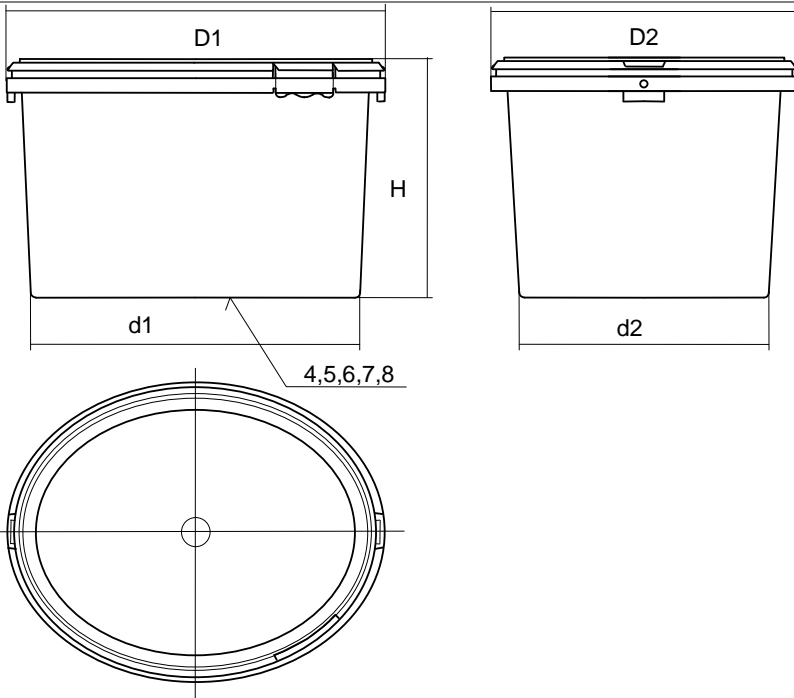

Bucket	
Material	Polypropylene Copolymer food approved
Fabrication	Injection moulded
Handle	Metal
Nominal Capacity	15ltr
Brimful Capacity	16.8ltr
Nominal Weight	436g +/-15
Pallet Quantity	400
Pallet Size	1200x800x1760mm
Weight per Pallet	226kg
Stock Colours	Non stock item 2-3 week lead-time

Dimensions	mm	Lid - DO1800-4	
Height	251 +/-1%	Material	Polypropylene Copolymer food approved
Top Diameter 'D1'	378 +/-1%	Fabrication	Injection moulded
Top Diameter 'D2'	294 +/-1%	Height	17mm +/-1%
Base Diameter 'd1'	323 +/-1%	External Dia's	379mm & 293mm +/-1%
Base Diameter 'd2'	238 +/-1%	Nominal Weight	138g +/-8
		Pack Size	50 per bag
		Stock Colours	Non stock item 2-3 week lead-time

Additional Information
4 pallet minimum order for coloured buckets Printing available please contact us for a quotation

PPREF	Issue	Date of Issue	Approved By
AT	A	08/05/07	Roy Miller