

PRODUCT SPECIFICATION SHEET

Product	UN Mark
EO1250 12.5ltr Oval T/E Bucket	N/A

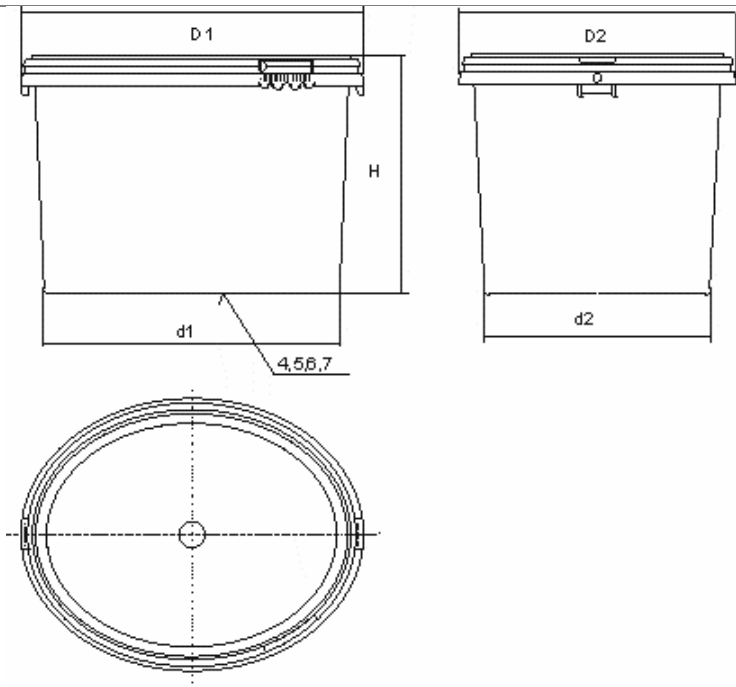

Bucket	
Material	Polypropylene Copolymer food approved
Fabrication	Injection moulded
Handle	Metal
Nominal Capacity	12.5ltr
Brimful Capacity	13.5ltr
Nominal Weight	350g +/-12
Pallet Quantity	450
Pallet Size	1200x800x1880mm
Weight per Pallet	203kg
Stock Colours	Non stock item 2-3 week lead-time

Dimensions	mm	Lid - DO1250	
Height	245 +/-1%	Material	Polypropylene Copolymer food approved
Top Diameter 'D1'	354 +/-1%	Fabrication	Injection moulded
Top Diameter 'D2'	274 +/-1%	Height	16mm +/-1%
Base Diameter 'd1'	299 +/-1%	External Dia's	352mm & 272mm +/-1%
Base Diameter 'd2'	219 +/-1%	Nominal Weight	120g +/-10
		Pack Size	50 per bag
		Stock Colours	Non stock item 2-3 week lead-time

Additional Information
4 pallet minimum order for coloured buckets Printing available please contact us for a quotation

PPREF	Issue	Date of Issue	Approved By
AT	A	08/05/07	Roy Miller

UNCONTROLLED COPY