

PRODUCT SPECIFICATION SHEET

Product	UN Mark
120ltr UN MHX (Multihandling) Drum	UN/Y1.4/200/**/GB/5104

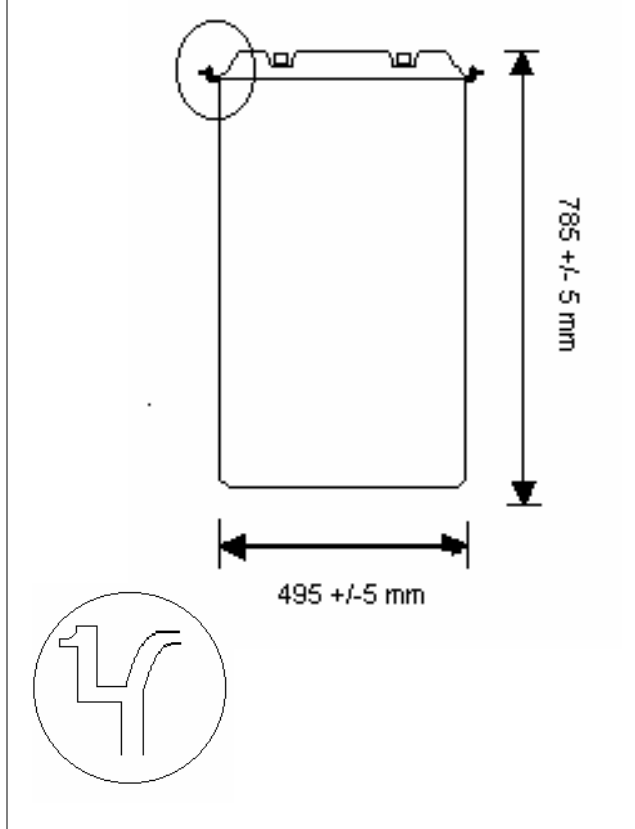

Body	
Material	High Density Polyethylene
Fabrication	Extrusion Blow Moulded
Nominal Capacity	120ltr
Brimful Capacity	137ltr
Nominal Weight	5.7kg +/-0.20
Min Thickness	2.5mm
Colours Available	Blue

Dimensions	mm	Closure System	
Height	785 +/-5	Position	Offset on Head
Diameter	495 +/-5	Closure Type	2" Buttress internal-threaded Bung
		Closure 1	2" Solid Bung
		Closure 2	2" Bung with 3/4" recess for tap insertion
		Buttress Thread	4mm pitch
		Torque	17Nm
		Material	Polypropylene
		Gasket	EPDM/White Nitrile

Additional Information

PPREF	Issue	Date of Issue	Approved By
WA	D	05/04/07	Roy Miller

UNCONTROLLED COPY